



ATECMAA
PACKAGING

GX 1.10

Automatic cycle stretch wrapping machine

For stretch CAST film or pre stretch film:

Excellent return on investment / hand film / keep the operator on other tasks

Flexible installation

Reliability / Robustness

Electromagnetic brake

Easy use

Adjustable cycles

- Simple control panel: On/Off (lockable control panel)
- Height of the pallet: up to 2400 mm (standard machine)
- Automatic detection of the height of the pallet
- Progressive start of the turntable
- Electromagnetic brake (patent pen-)
- 20 to 150 palets/day
- Embedding belt optional
- Weigh integrated scale within the wrapping time: optional



Flexibility of the logistics service: 230 V single phase plug in + earth

Any type of CAST stretch film up to 23 μ and pre-stretch film up to 9 μ available on the market

TECHNOLOGIES ET PROCESS D'EMBALLAGE

32, rue de Charette • 28140 TERMINIERS - FRANCE
Tél : 33 (0)2 37 18 58 13 - Fax : 33 (0)2 37 32 11 34 ou 33 (0)2 37 32 14 22
www.rassinouxa.com - Commercial production : clients@rassinouxa.com
Comptabilité : compta.mf@rassinouxa.com - Qualité : qualite@rassinouxa.com

RASSINOUX - SA au capital de 1 372 754 € - SIRET 353 267 446 00014 - APE 284B - FR 41 353 267 446 - RCS 353 267 446 Chartres



ATECMAA
PACKAGING

GX 1.10

Automatic cycle stretch wrapping machine

TECHNICAL FEATURES:

- Installed power:	1 KW
- Power:	230V Single Phase 50hz + earth
- Manufacture:	IP54

Dimensions:

- Length :	2466 mm / 2591 mm*
- Width:	1812 mm / 1937 mm*
- Overall height :	2900 mm / 3400 mm*
- Weight:	420 Kg (or 490 kg*)

Accepted dimensions of the pallets:

- Length:	1200 mm
- Width:	800 ou 1000 mm (or 1200 mm*)
- Height:	2400 (or 2900 mm**)
- Maximum load:	1500 Kg

ASSEMBLED PARTS OF THE MACHINE:

- **Column:** folded sheet metal made.

- Maximum pallet + Load wrapping height:	2572 mm or 3072 mm**
---	-----------------------------

- **Bobbin trail** powered by a motor reducer with a frequency converter, drive with pitch chain.

- Fixed speed
- Detectors to stop at the top and the bottom
- Cell for automatic detection of the height of the pallet
- Tightens automatically tanks to a patented bobbin brake and electromagnetic brake adjustable by a potentiometer
- Easy loading and unloading of the bobbin— width 500 mm

- **Lowered turntable**, protected by a peripheral belt

- Height:	79 mm
- Diameter:	1600 mm (or 1750 mm optional)

Powered by motor-reducer, drive with 15.8 mm pitch chain

- Speed rotation:	12 rev/min
-------------------	-------------------

Speed progressively lowers during the « stop phase »

Designed to be moved with a forklift truck (except for non standard turntables with diameters of 2000 et 2400 mm)

Drive with 15,8 mm pitch chain

Polyamide peripheral roller bearings

A tooth disc supported roller bearing for combined loads

- **IP level of protection** IP 54 (motor-reducer IP 55)

- Colour: anthracite grey RAL 7016. Yellow turntable RAL 1018

- Polymerized epoxy polyester painting, 80 to 100 microns with anti-corrosion treatment

TECHNOLOGIES ET PROCESS D'EMBALLAGE

32, rue de Charette • 28140 TERMINIERS - FRANCE
Tél : 33 (0)2 37 18 58 13 - Fax : 33 (0)2 37 32 11 34 ou 33 (0)2 37 32 14 22
www.rassinouxa.com - Commercial production : clients@rassinouxa.com
Comptabilité : compta.mf@rassinouxa.com - Qualité : qualite@rassinouxa.com



Automatic cycle stretch wrapping machine

ATECMAA
P A C K A G I N G

HOW TO USE:

- Load the pallet on the turntable
- Start the cycle
- Wrapping phase starts according to the chosen settings.
- End of the cycle with the pallet positionned for next start.
- Film cut by hand and and pre-fixing on the turntable
- Load a new pallet



TYPES OF FILM: Any kind of stretch flim up to 23 microns thick (width 50 to 500 mm – diameter of the bobbin 250 mm - Diameter of the mandrel 76 mm)

OPTIONAL: * turntable with a diameter of 1750 mm, ** reheightened column 500 mm, *** weigh intergrated scale within the wrapping time, **** ramp or embedding belt

USE:

Functions		« Standard » programmes	Optional
Cycles	Full cycle (wrapping while rising and lowering)	<input checked="" type="checkbox"/>	
	half cycle (wrapping while rising only)	<input checked="" type="checkbox"/>	
	Full cycle with application of the top sheet (stops at the top of the pallet to apply the sheet)	<input checked="" type="checkbox"/>	
Film stretching	Electromagnetic brake	<input checked="" type="checkbox"/>	
Speed of the turntable	Adjustable	<input checked="" type="checkbox"/>	
Speed of the bobbin trail	Adjustable	<input checked="" type="checkbox"/>	
N° of rev. at the bottom	Adjustable	<input checked="" type="checkbox"/>	
N° of rev. at the trop	Adjustable	<input checked="" type="checkbox"/>	

These levels enable wrapping of most types of loads.

TECHNOLOGIES ET PROCESS D'EMBALLAGE

32, rue de Charette • 28140 TERMINIERS - FRANCE
 Tél : 33 (0)2 37 18 58 13 - Fax : 33 (0)2 37 32 11 34 ou 33 (0)2 37 32 14 22
www.rassinouxa.com - Commercial production : clients@rassinouxa.com
 Comptabilité : compta.mf@rassinouxa.com - Qualité : qualite@rassinouxa.com

RASSINOUX - SA au capital de 1 372 754 € - SIRET 353 267 446 00014 - APE 284B - FR 41 353 267 446 - RCS 353 267 446 Chartres



ATECMAA
PACKAGING

DIMENSIONS:

GX 1.10

Automatic cycle stretch wrapping machine

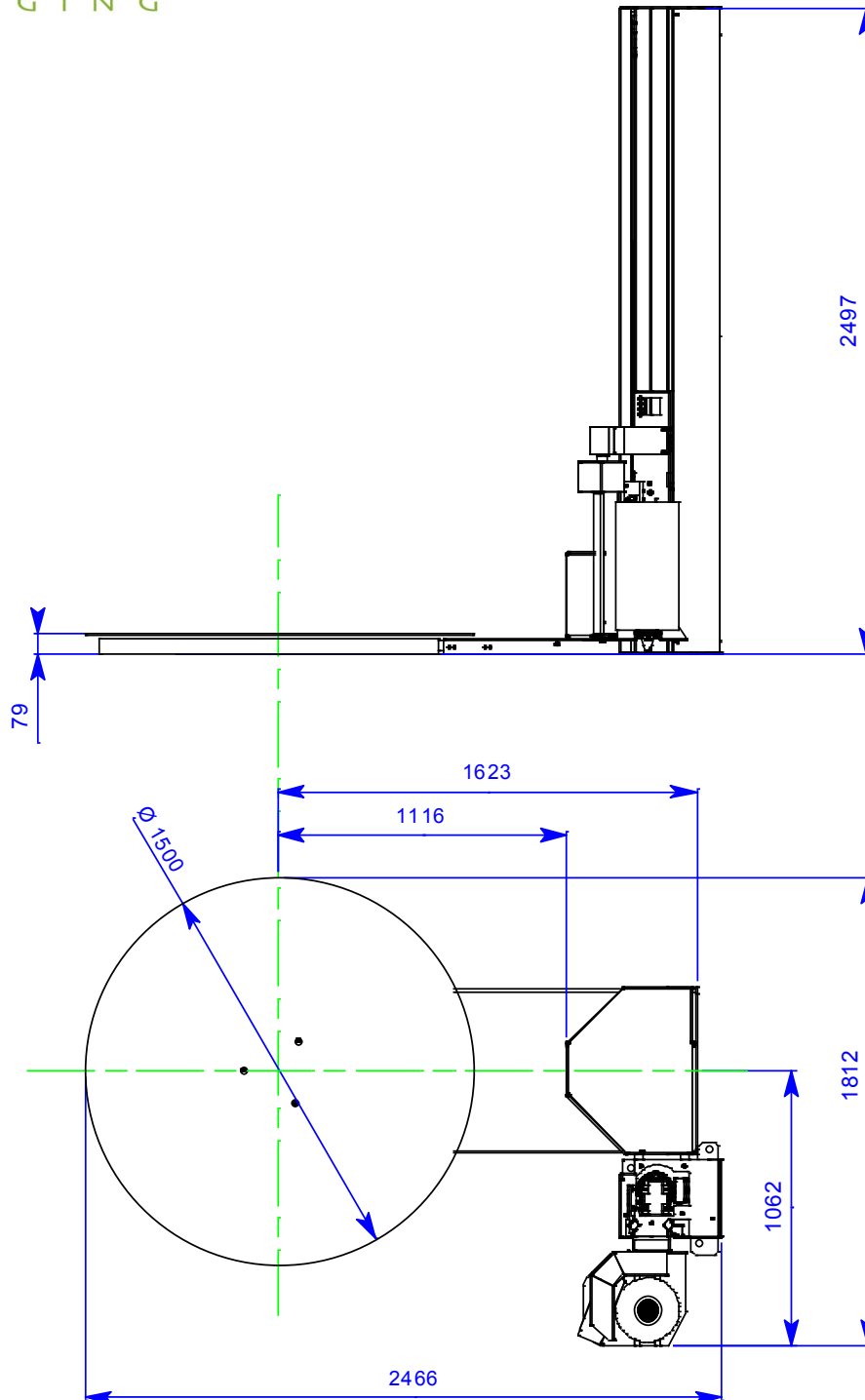

European made machines in compliance with the applicable EU regulations (CE)

NON CONTRACTUAL DOCUMENT:

Considering the evolution of the machines, we may change at any time our products, dimensions, texts and drawings, without any prior notice
The complete or partial reproduction without express permission is prohibited.

TECHNOLOGIES ET PROCESS D'EMBALLAGE

32, rue de Charette • 28140 TERMINIERS - FRANCE

Tél : 33 (0)2 37 18 58 13 - Fax : 33 (0)2 37 32 11 34 ou 33 (0)2 37 32 14 22

www.rassinouxa.com - Commercial production : clients@rassinouxa.com

Comptabilité : compta.mf@rassinouxa.com - Qualité : qualite@rassinouxa.com