

TOSA

STRETCH WRAPPING TECHNOLOGY

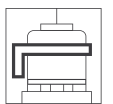

Rotating ring

TOSA 150

THE STRETCH WRAPPER TOSA 150



The Pallet Stretch Wrapper Model TOSA 150 with rotating ring is positioned in the top segment of the market, being able to respond to the highest capacity demands thanks to the **ring rotation speed of 65 rpm** and the possibility to use **film rolls 500 mm or 750 mm wide**.

The machine has been designed specifically **to minimize the maintenance costs and the film consumption**.

MACHINE BASIC CONFIGURATION

- Automatic powered pre-stretch with ratio up to 400%.
- Sealing unit with contrast-bar for welding the film without any contact with the product.
- Inverters and Encoders for maximum precision for movement control.
- **Operator panel 10" colour** with graphical interface for easy use and understanding:
 - manual movement operations;
 - production data in real time (cycle times, film consumption);
 - graphic visualization of machine faults and trouble-shooting designed to make it easier and quicker for the operator's intervention.
- It is possible to prepare wrapping programs, dedicated to each product format with variable parameters such as film tension, wrapping cycle type, spiral pitch overlap, film pre-stretch and position of film roping (option).

REDUCTION OF STRETCH FILM CONSUMPTION

- The use of a film roll 750 mm wide allows not only to reduce the number of film wraps needed for completing the wrapping cycle, but also to cover a wider surface of the product with each wrap, increasing the stability of the load.
- Film roping system functions by reducing the film width from the bottom and the top by means of two independent compression wheels, driven by brushless motors with an encoder, which allows the setting of the film band width, in any position on the pallet with precision.
- The pallet lifter allows to also wrap the base of the pallet with the film rope.

REDUCTION OF MAINTENANCE COSTS

- Up-down movement of the ring by means of toothed belts, completely maintenance and lubrication free, and designed in a Fail Safe configuration, with double belts for each machine column.
- Gearless direct motorization of the ring lifting system, with no need for maintenance.
- Use of lubrication free guiding wheels and of special guide ways for the ring carriage, requiring lubrication only on a greatly reduced frequency and only in case of operating in highly dusty environments.
- Lubrication free bearings are used on the machine.



OPTIONAL TOSA 150



PRE-STRETCH WITH DOUBLE BRUSHLESS MOTORIZATION

The two pre-stretch rollers are independently driven by two state-of-the-art brushless motors.

Allowing the possibility to program wrapping cycles with a pre stretch ratio variable from 0 to 400%.

Optimizing film distribution on the pallet during all wrapping phases



TOP SHEET DISPENSING UNITS FOR DUST PROOF PROTECTION

The systems for the application of a plastic top sheet to protect the pallet load can be supplied also with two film-roll positions, which can be automatically selected to increase the film autonomy reducing the machine stops for film-roll changeover. Available also with an automatic top sheet film roll changing system, eliminating machine stops required to replace the exhausted film-rolls.

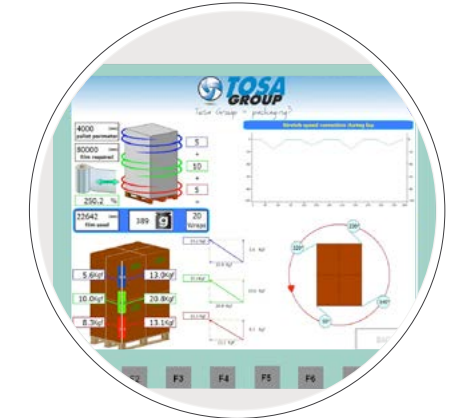

SMART WRAPPING TECHNOLOGY

Allows for the possibility to detect and historicize data, such as, film consumption, cycle times, product data, wrapping programs, film features and real pre-stretch used for each wrapped pallet load. Allows for the possibility to automatically optimize the distribution of the film during the wrapping phases according to the detected size of the palletized load.

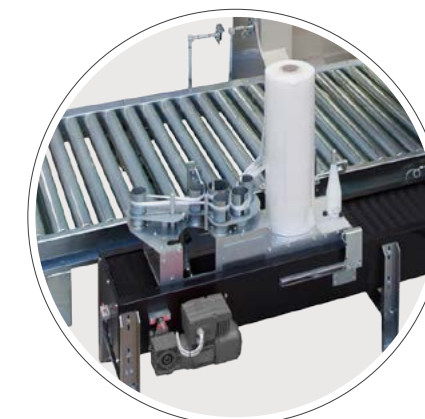

AUTOMATIC STRETCH FILM ROLL CHANGE SYSTEM

The automatic stretch film roll change system, model TOSA 801, allows the replacement of the exhausted film-roll in 30 seconds with no operator intervention. **Patented in Europe and America.**



MOTORIZED PANTOGRAPH TYPE TOP PRESSER

This motorized device ensures maximum flexibility of use, reduction of overall height of the equipment and optimization of energy consumptions where a top presser is required. Thanks to the use of lubrication free bearings, this unit does not need any maintenance.



AUTOMATIC APPLICATION OF VERTICAL CORNER POSTS

This system for the automatic application of vertical corner posts is to provide protection to the corners of pallet loads, where additional protection is required; it is available with corner post magazines for different sizes.

TECHNICAL LAYOUT

TOSA 150

Voltage	400 V three-phases – 50 Hz. + N.	Required film	PE stretch film
Installed power	21 kW	Output	up to 150 pallet/hour according to wrapping cycle and pallet height
Compressed air feed	5-6 bar	Max pallet dimensions	1000 x 1200 x H. 2000 mm
Compressed air consumption	230 NI/cycle		

All technical specifications are subject to change without notice.

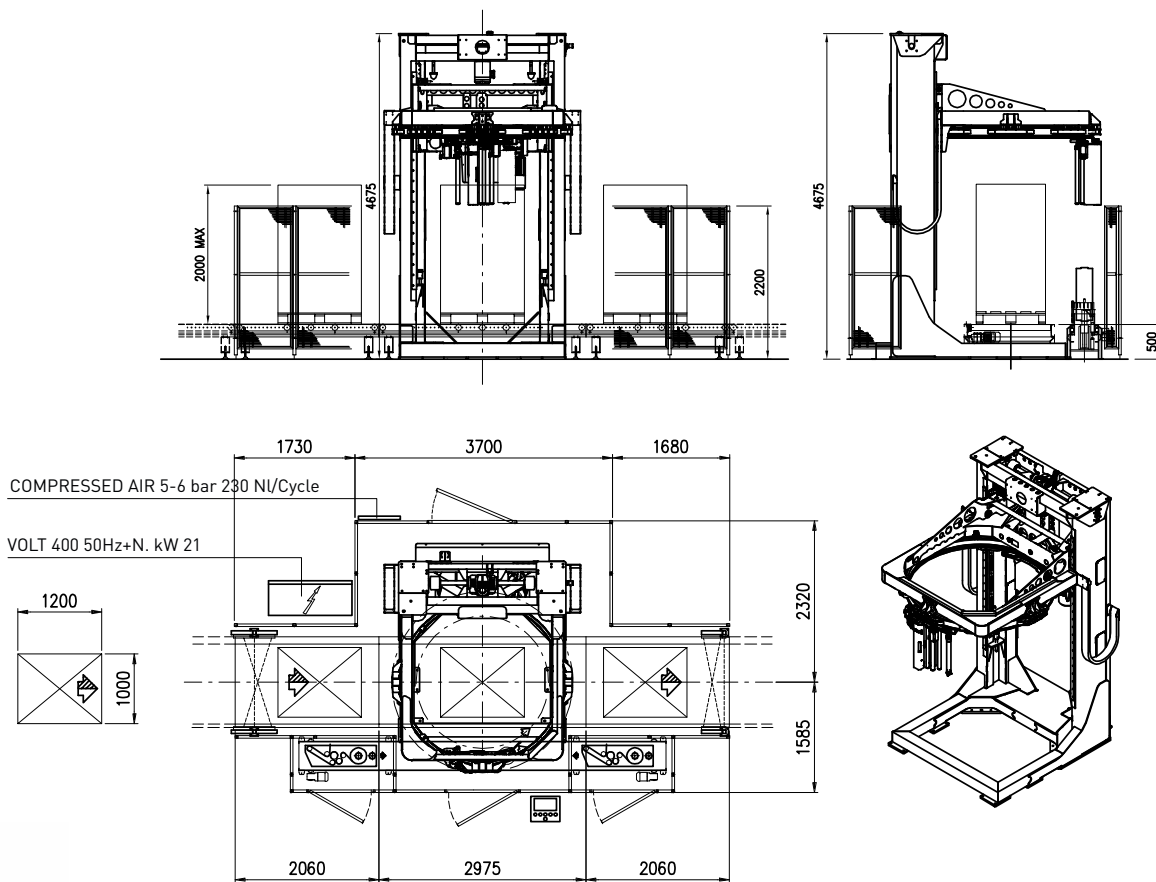

TOSA S.p.a.

Corso IV Novembre, 109-111
 12058 S. Stefano Belbo (CN), Italy
 Tel. +39 0141 841000
 Fax +39 0141 841099
 info@tosa.it

tosagroup.net

