

EUROPAL 49

Simple, Flexible, Powerful



 **LORENZ PAN**
the specialist in palletizing

www.lorenzpan.com

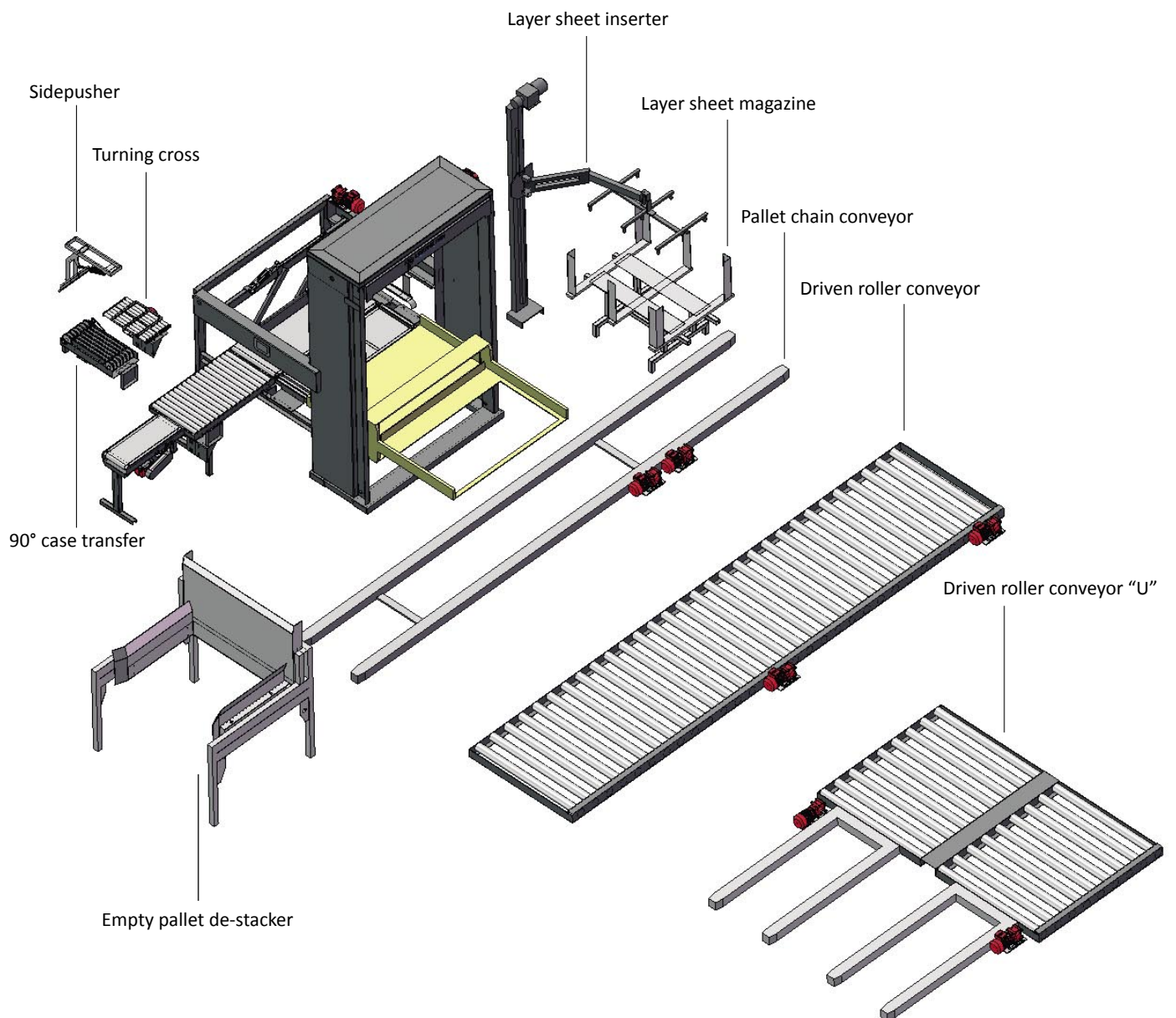

Technical data:

Pallet size: max. 1200x800 mm
Pallet height: max. 2100 mm
Weight per carton: max. 20 kg
Weight per layer: max. 180 kg
Capacity: 12–30 cases per minute
 (depending on case size and layer pattern)

Case:

Max case height: 300 mm
Min case height: 100 mm
Max case diagonal: 500 mm

Case size:	Length	Width
	350 mm	350 mm
	400 mm	300 mm
	450 mm	220 mm
	480 mm	140 mm
	500 mm	120 mm

Examples of possible layer pattern:

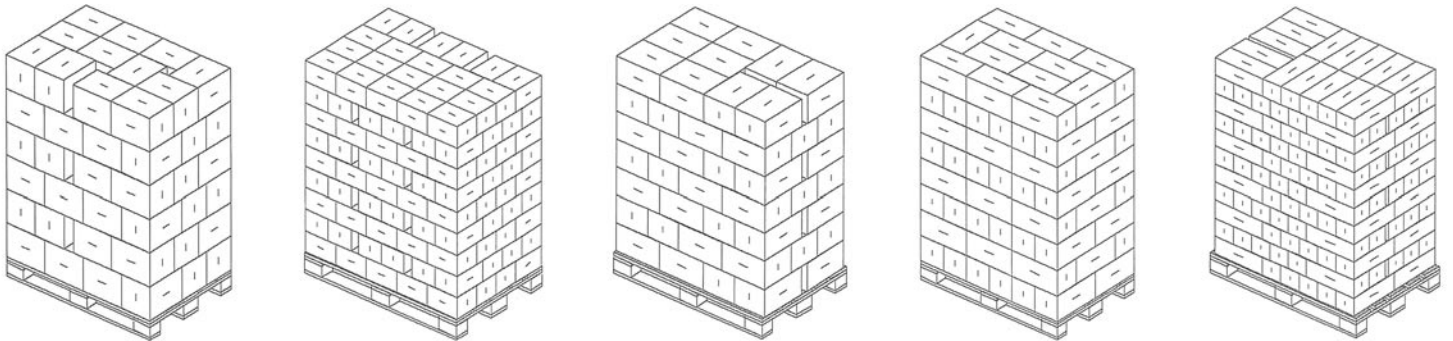

Examples of possible cases:



PLANT MEASURE:

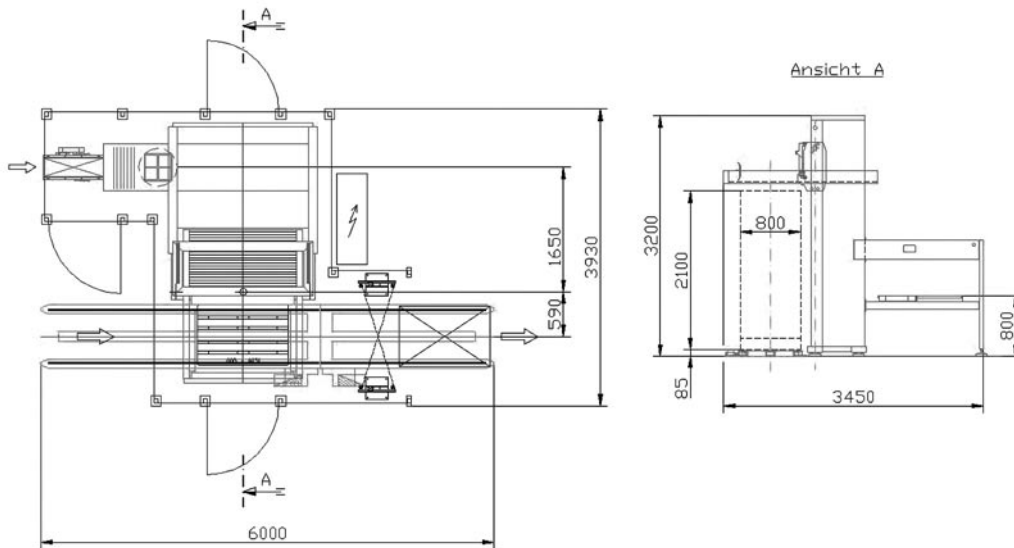

LAYOUT OPTIONS:

In line case infeed

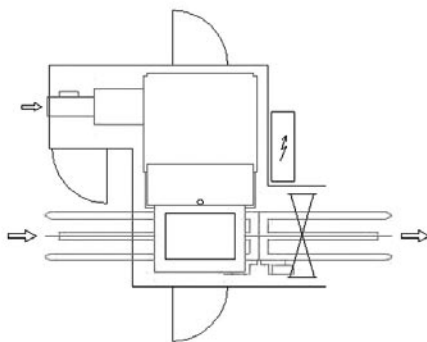

90° case infeed

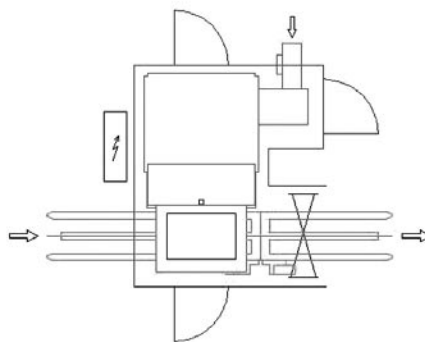

Layer sheet inserter

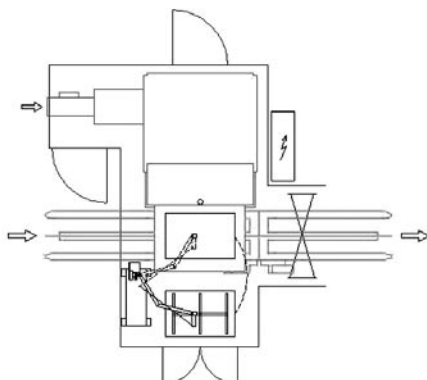

Empty pallet de-stacker

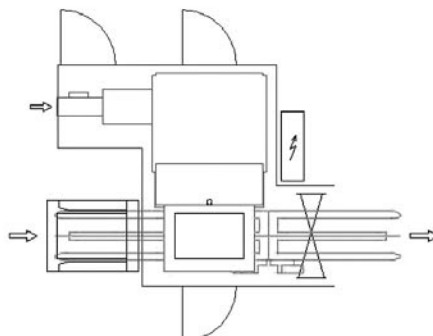

Features:

- robust- and material efficient design
- low energy- and maintenance costs
- high quality components
- simple and fast installation and start-up
- system-options are easy to ad – if required at a later stage
(pallet dispenser, pallet roller conveyor and layer sheet applicator)
- left or right infeed, easy to change

Simple:

easy to operate and to maintain
robust and durable

Economical:

average consumption 0,9 kw/h
(a comparable palletizing robot needs up to 4,5 kw/h)

Flexible:

handling of wide range of products (trays, cartons, shrink wrapped trays, trays with lid, ...)
fast- and easy product change (max. 2 min.)

Perfect and accurate:

precise loaded pallets – due to mechanical layer squaring
exact positioning of pallet load on pallet

Safe and clean:

design in U-shape-profiles (no box sections)
palletizer highly visible from outside

We are specialized in palletizing with the target to offer our customers suitable palletizing solutions

About the company: Family owned limited Company located at Bolzano, South Tyrol (Italy). Since 1982 we are constructing palletizing plants and in total we have installed more than 850 palletizing plants worldwide for the full satisfaction of our customers. Our product range: comprises following systems with highly standardised interfaces to up- and downstream machines:

- **Conveyors:** (cases, pallets; different systems of conveyors, dividers, elevators)
- **Palletizers:** Layer-Palletizer in modular design and Robotic-Palletizer (ABB, KUKA, FANUC)
- **Pallet wrapping:** Turntable machine, Rotating arm machine, Palletizingwrapper
- **Scada System:** several Bus-Systems, with supervising system, data record systems, Visualising

We are supplying Palletizing plants into different sectors of industry, Food and Non-Food. One of our core business is the palletizing at freezer environment (down to -25°C) for deep frozen products.

Our competitive advantages are:

- **High value at a competitive price** enabled by modular design and high standardisation
- **Simple- and highly functional design**, small footprint, low wear, low maintenance costs, simple to operate
- **Flexibility** technical updated machines in manufacturing
- **long experience** of our engineers in project Management



Kravoglstr. 10
I-39100 BOZEN
t: +39 0471 200196
m: info@lorenzpan.com



Headquarter Bozen,
Kravoglstr. 10, I-39100 BOZEN



Facility Leifers,
Franklinstr 10, I-39055 LEIFERS



Facility Pontives,
St-Peter – Gewerbezone Pontives 13
I-39040 LAJEN



Facility Hronská Breznica,
Hronská Breznica 104, SK-96611 Trnavá Hora



Interior view: Hronská Breznica